

# Problem Pets

story by David Hill | illustrated by Toby Riddle

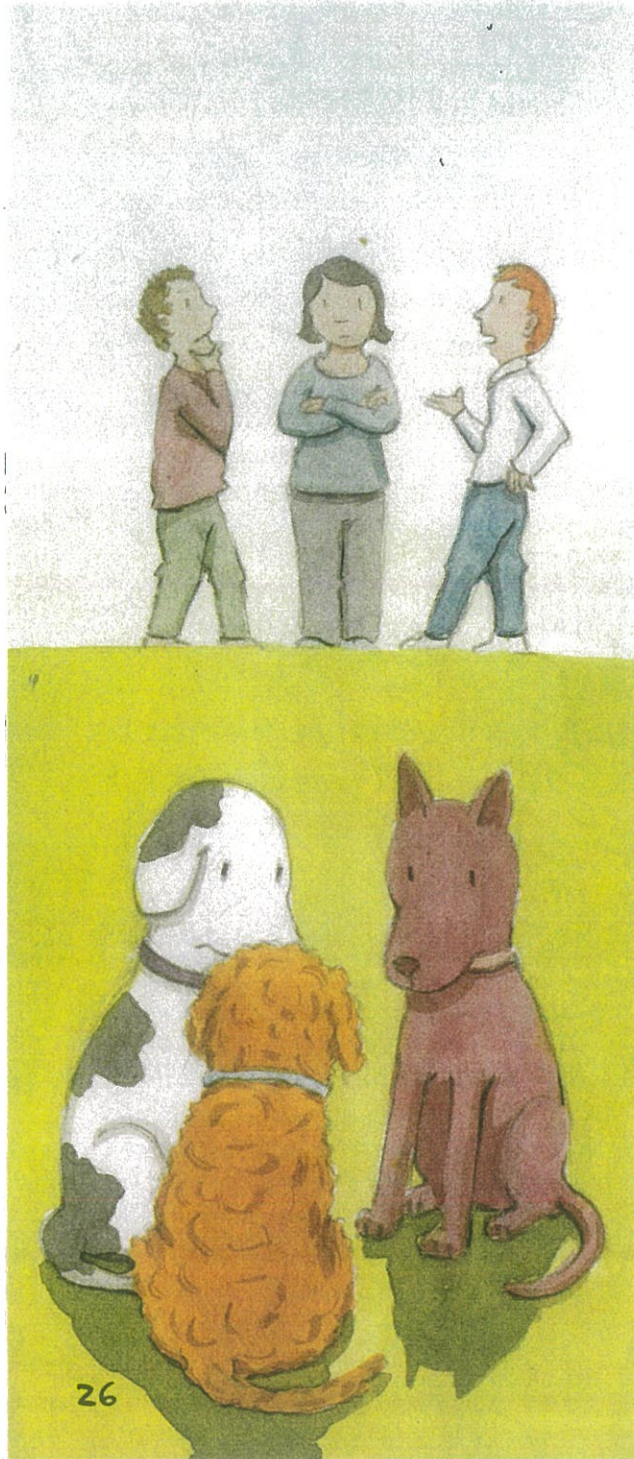

'IS YOUR PET hard to train?' asked Rik.

Jess sighed. 'Oh, man! He's hopeless! He can't learn anything properly!'

'Same as mine,' Ben told them. 'She's the weirdest pet you'll ever meet!'

'You should see mine when we go for walks,' Rik said. 'He's always pulling on the lead! Or else he keeps stopping, or he heads off somewhere I don't want to go. He's seriously strange!'

'You should see mine when we play a stick-throwing game,' said Jess. 'He makes so much noise. Or he goes rushing all over the place or else we have this big fight about getting the stick back. He's seriously silly!'

'You should see mine when we go swimming,' Ben told them. 'She chucks herself into the water and sprays everyone! Otherwise she goes splashing round in big circles or she makes heaps of noise. She's seriously embarrassing!'

'I wonder if anyone has a pet as silly as mine?' said Rik.

'I wonder if anyone has a pet as loud as mine?' said Jess.

'I wonder if anyone has a pet as mad as mine?' said Ben.



'Mine does try hard,' Rik went on. 'He's good about eating. He doesn't make a fuss or leave bits of food lying everywhere.'

Jess nodded. 'Mine is friendly. He likes to play, and he never sulks.'

Rik nodded too. 'Mine is gentle. She doesn't bite, and I can trust her with the little ones.'

'But mine is such a hard pet to train!' Rik exclaimed. 'I can't stop him from doing all this silly running around!'

'Same with mine,' Jess said. 'I can't train him to stop being noisy with people we meet in the street.'

'And mine,' said Ben. 'I can't train her to go at the right speed or to come when I call her.'

'Will our pets ever be properly trained?' asked Rik.

'I don't think so,' said Jess.

'Neither do I,' said Ben.

Rik woofed sadly. Jess thumped her tail. Ben shook his head till his ears flapped.

'No,' they all sighed together. 'There's nothing as impossible to train as humans!' ■

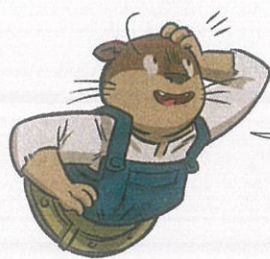

Ooh,  
I wonder if  
humans have to  
go to training  
school?

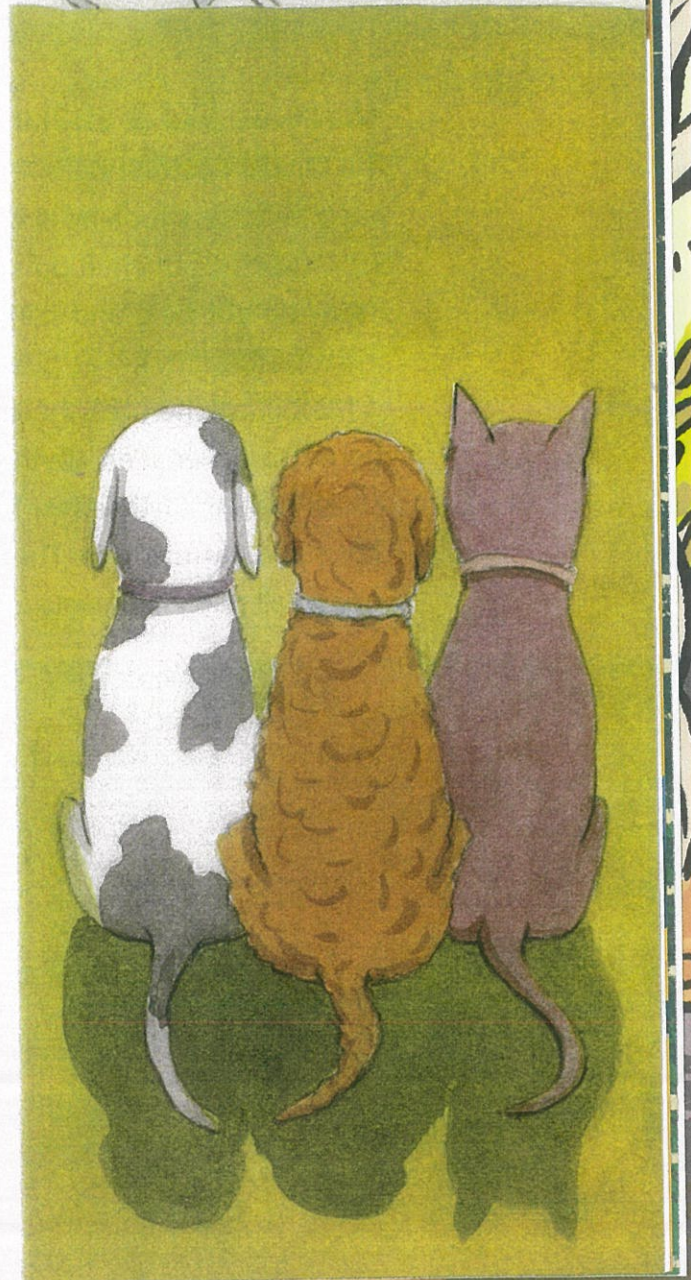



List 1	List 2	List 3	List 4
run	forgot	occur	occur
running	forgotten	occurred	occurred
sun	pump	appear	occurrence
sunny	pumped	appeared	refer
places	sing	travel	referred
same	singing	travelling	referring
different	same	similar	anxious
live	different	different	apprehensive
people	country	environment	nervous
view	climate	neighbour	cowardly



WEEK 3



# Unit 23 Adverbials - When Phrases

Adverbial phrases can give more meaning to a sentence.  
 Phrases do not have a verb and do not make sense on their own.  
 Many adverbial phrases tell us WHERE or WHEN.



**WHEN** → The bee worked busily during the day. ← when? During the day.  
 The spider will finish the web by tomorrow night.

1 The phrases in the boxes below tell us where or when.  
 Shade the boxes that tell **when**.

in the winter	at midnight	in the evening
behind the door	in the morning	on the rock
under the leaf	before sunset	in the book
below the twig	by midnight	on the web

2 Circle the letter that the shading above most looks like. **F T H L**

3 Shade the **when** phrase in each sentence below.

- a We played in the puddles (after the rain) (in the backyard).
- b The sun rises (in the morning) (over there).
- c We go water-skiing (on the lake) (in summer).
- d (By afternoon) (the temperature of) the sun was too hot.



in the winter                      at midnight                      during the holidays  
 in the morning                      after school                      after dinner

4 Use the **when** phrases in the box above to finish the sentences.

- a Snow falls \_\_\_\_\_.
- b It is very dark \_\_\_\_\_.
- c They went to soccer training \_\_\_\_\_.
- d Lucas eats breakfast \_\_\_\_\_.
- e You go to bed \_\_\_\_\_.
- f We went to the zoo \_\_\_\_\_.





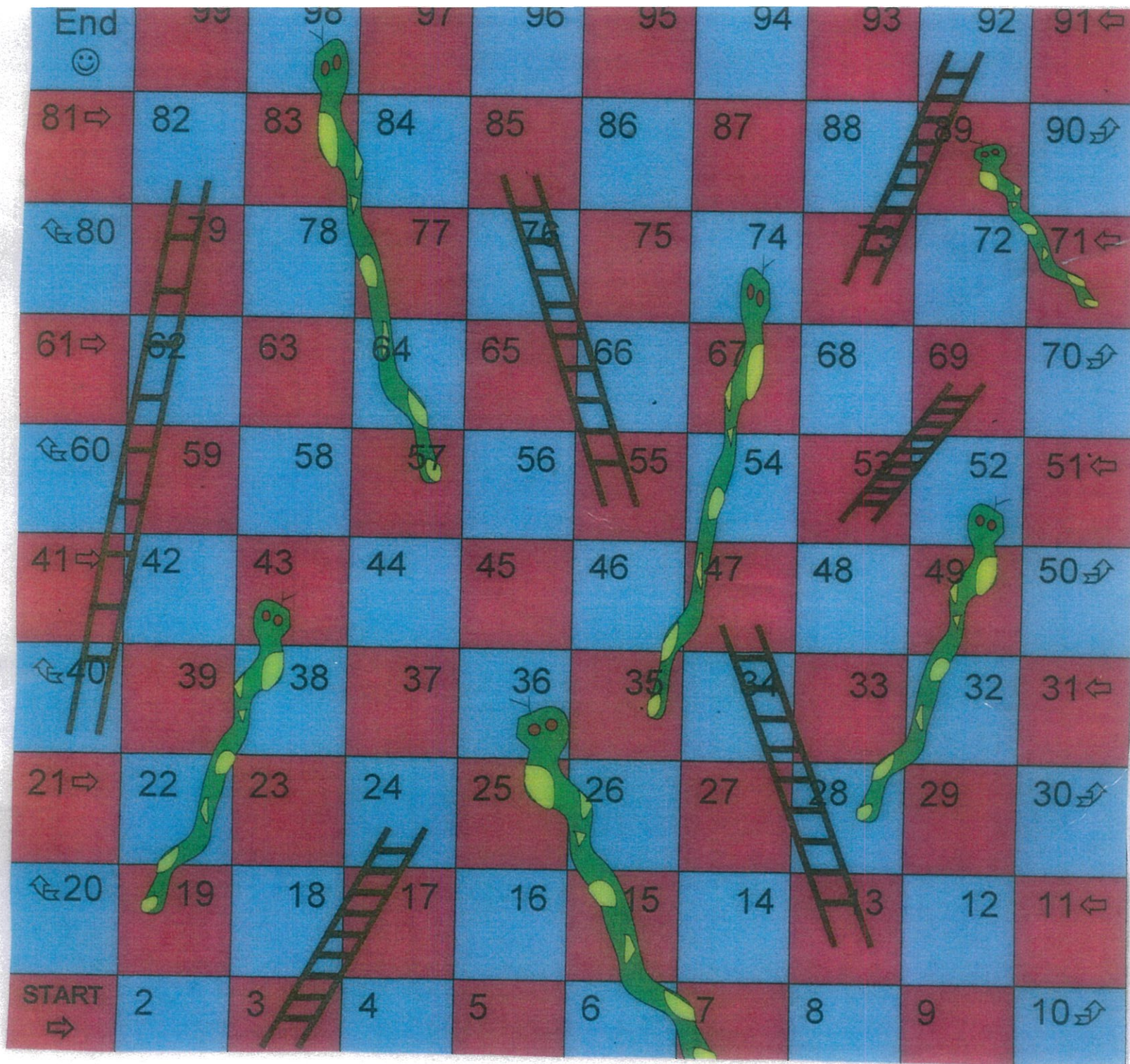



## Lions

- ⓪ Lions are the second largest cat species in the world.
- ⓪ Lionesses are better hunters than males and do most of the hunting for a pride.
- ⓪ In the wild, lions rest for around 20 hours a day.
- ⓪ Most lions found in the wild live in southern and eastern parts of Africa.

I love lions, but I think that they are the most ferocious animals in the world. They have huge teeth that they use to bring down their prey. I believe that all other animals are terrified of lions. They are better than any other animal in the wild.



## Lions

1. Write **F** for fact or **O** for opinion next to each statement.
  - \_\_\_ Lions are the second largest cat species in the world.
  - \_\_\_ Lions are better than any other animal in the wild.
  - \_\_\_ In the wild, lions rest for around 20 hours a day.
  - \_\_\_ I think they are the most ferocious animal in the world.
  - \_\_\_ Lionesses are better hunters than males.
2. What is your opinion of lions?
3. What are some of the ways that you can tell the difference between a fact and an opinion?
4. Make a list of some common words that you might find in an opinion.

### CRAZY CREATIVE CHALLENGE

Draw a lion.

Write any facts you know about lions on the body.

Write your opinions about lions around the body.

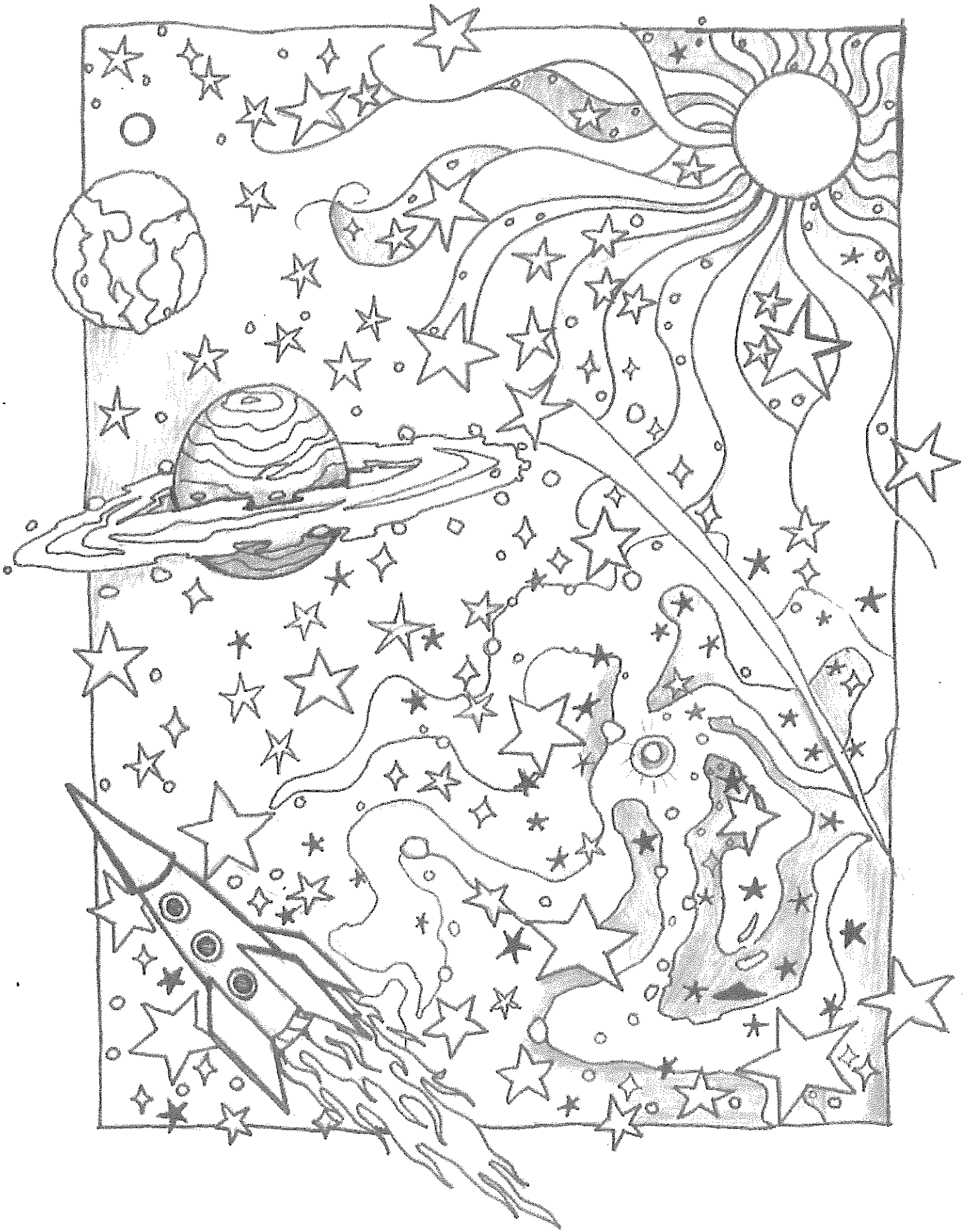

# WATER SAFETY WORDSEARCH

R U J G B P Q N J J H S S T S F Z  
X U H B Z Y B A R H U V S N K W V  
P L L F Q X X Q P A R V O S A J B  
U I G N I R Y T E F A S V T P X W  
K F U K V G B D S C S E E B Z Q O  
K E V F Q B C G I E Q R X Z U H L  
F G L E U L Y W L X S N F O A O L  
L U A G U Y X G A A K I M V G Q A  
O A H D X C N T F T R Q E U F D H  
A R I T R I S E M S E F D W I P S  
T D P W M O T E T O U R T Z O B R  
R T W M R Y W A R N P M Y V S X V  
W R I Q U B I N D L O G P S E K G  
C W A Y D D U B N A R C W L Q S G  
S G Y I K T E K C A J E F I L Y D  
N O D I V I N G S T Q S V M G Q C  
Q D T Y D A X M A C I D E E P A A

**SAFETY RING**

**FIRST AID KIT**

**DEEP**

**SHALLOW**

**RESCUE**

**SWIMMING LESSONS**

**NO DIVING**

**LIFE JACKET**

**WATER SAFETY**

**WATER**

**HAVE FUN**

**FLOAT**

**BUDDY**

**DROWN**

**LIFE GUARD**



# Dragonfly's Surprise

story by Dannielle Viera | illustrated by Sheree Fiala

A BURST OF squeaks, squawks and snarls swirled around the Great Cave. Dragonfly darted here and there, trying to help. Two powerful paws suddenly slammed down onto the stone table in the centre of the cave. 'What are we going to do about the dragon?' bellowed Bear.

The chiefs of the animal clans glanced at one another. Eagle swooped down from a rocky outcrop. 'I tried to soar over the valley, but the wretched dragon has wings of blistering speed. My feathers soon felt the singe of its sizzling breath.'

Elephant raised her trunk and trumpeted. 'I tried to push my way through to the summer feasting fields, but the creature has claws like knives. My leathery hide ran red with blood.'

Silence fell as Elephant's words wafted away. 'Has anyone actually asked the dragon if we can travel through the valley?' buzzed Dragonfly.

Lion threw his head back and roared. 'The dragon scorches and slashes whenever we come near. Is anyone brave enough to face such a demon?'

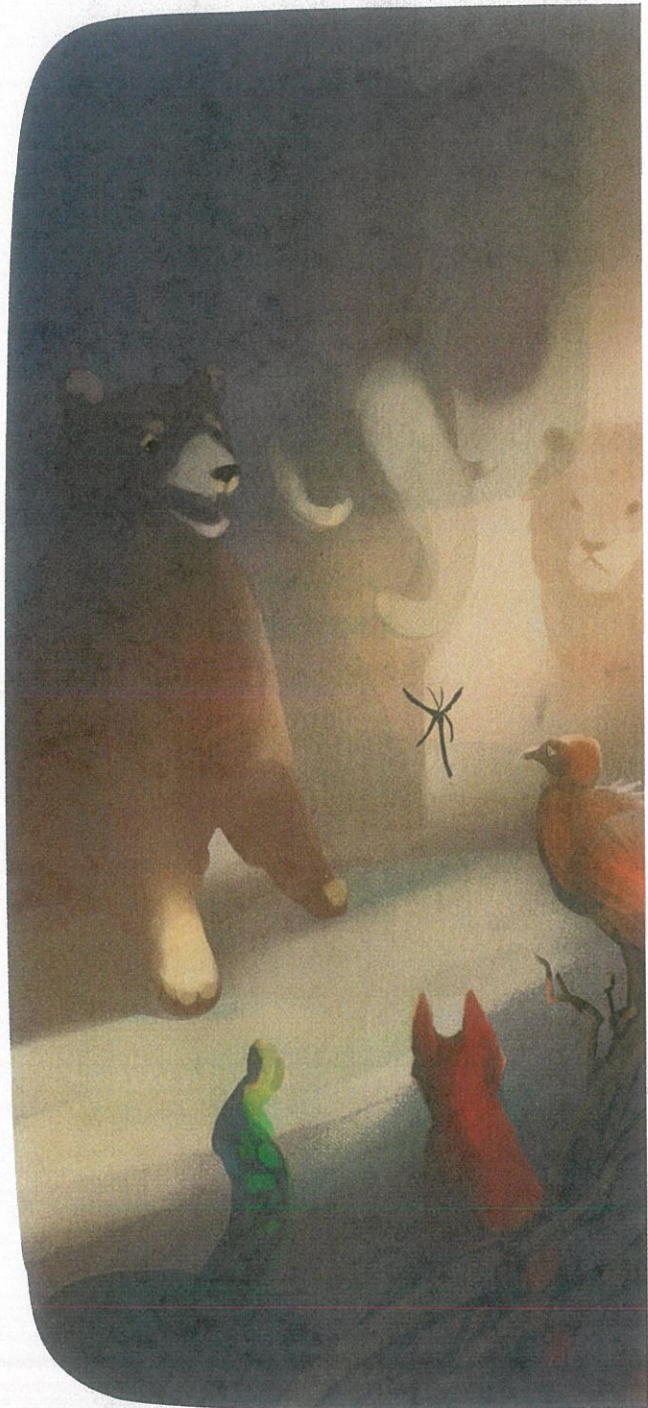





Nobody spoke. Dragonfly looked around as the animals stared sheepishly at the ground. 'I am brave enough,' he said.

Thunderous laughter echoed around the cave. Bear bent down and peered at Dragonfly. 'No, little one—this is a matter for the animals,' he growled, and swiped his paw. Dragonfly tumbled out of the cave and landed on the dirt with a small thud.

Shaking slightly, Dragonfly stood and tapped each foot in turn. Confident that he was okay, he turned to gaze at the jagged peaks of the Dark Mountains. He took a deep breath and flew towards them.

\* \* \*

As he neared the valley, Dragonfly noticed the beast curled up at the entrance. Scales shimmered in the sunlight as the dragon's chest rose and fell in sharp bursts. Glittering diamonds studded the dragon's cheeks. No, wait ...

'He's crying,' Dragonfly whispered.



He landed lightly on the end of the dragon's nose and said, 'Hello, cousin.'

The dragon squinted at the tiny insect and sniffed. 'Who are you?'

'Don't you recognise me?' Dragonfly asked. 'I have wings and a long tail, just like you. I'm a dragon too.'

The dragon's eyes crinkled and he almost smiled, before another tear slid down his cheek.

'Why are you sad?' Dragonfly asked.

'You are the first creature to speak to me since I arrived in the valley. I tried to talk to an eagle and an elephant. But they ignored me.'

Dragonfly rubbed his face with one of his front legs. 'Maybe there's something I can do.'

\*\*\*

A low drone from the cave revealed that the animals were still deep in discussion. Dragonfly hovered at the mouth of the cave. In his loudest voice, he shouted, 'Quick! Come here!'







The animals stumbled out of the cave and stopped in their tracks. Dragonfly waved at them from the top of a scaly head. 'I'd like you to meet my new friend, Dragon,' he said.

Nobody uttered a sound.

'Don't you have a question for Dragon?' asked Dragonfly.

Bear stormed to the front. 'Why did you attack Eagle and Elephant?'

'I didn't,' Dragon said. 'I was trying to talk to them. I'm sorry if I accidentally hurt them.' A teardrop plopped to the ground with a splash.

Elephant rumbled gently. 'Can we please travel through the valley to the summer feasting fields?'

'Yes,' said Dragon, 'as long as you pay the toll.'

The animals frowned at one another.

'The cost is a conversation with me.' Dragon bowed his head.









'That is a price we are willing to pay,' Dragonfly declared, and the animals all nodded happily. ■

Being  
friendly works  
wonders!





PROPERTIES OF 3D SHAPES TABLE

	Names	Faces	Edges	Vertices
				
				
				
				
				
				
				
				



## Stage 2 – Three-dimensional space

Name: \_\_\_\_\_ Class: \_\_\_\_\_ Date: \_\_\_\_\_

### Stage 2 – Three-dimensional space

#### Question 1 – understanding features of 3D objects

#### Key ideas

Name and describe the following 3D objects.

a)

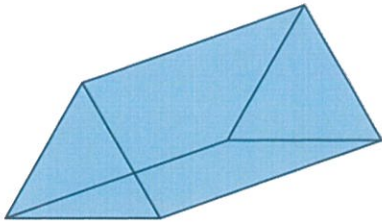

Name: \_\_\_\_\_

Description: \_\_\_\_\_

\_\_\_\_\_

\_\_\_\_\_

\_\_\_\_\_

\_\_\_\_\_

\_\_\_\_\_

b)

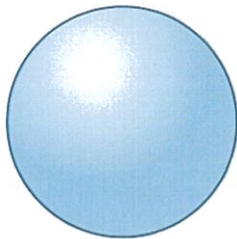

Name: \_\_\_\_\_

Description: \_\_\_\_\_

\_\_\_\_\_

\_\_\_\_\_

\_\_\_\_\_

\_\_\_\_\_

\_\_\_\_\_

Identify, describe and compare features of prisms, pyramids, cylinders, cones and spheres



## 3D SHAPES QUIZ 2

Question 3 – making models of 3D objects

Practical activity 

Deconstruct an everyday package of a prism to create a net.  
Draw your net below.

Key ideas

Create  
nets from  
everyday  
packages



# 1 Cm. Isometric Paper

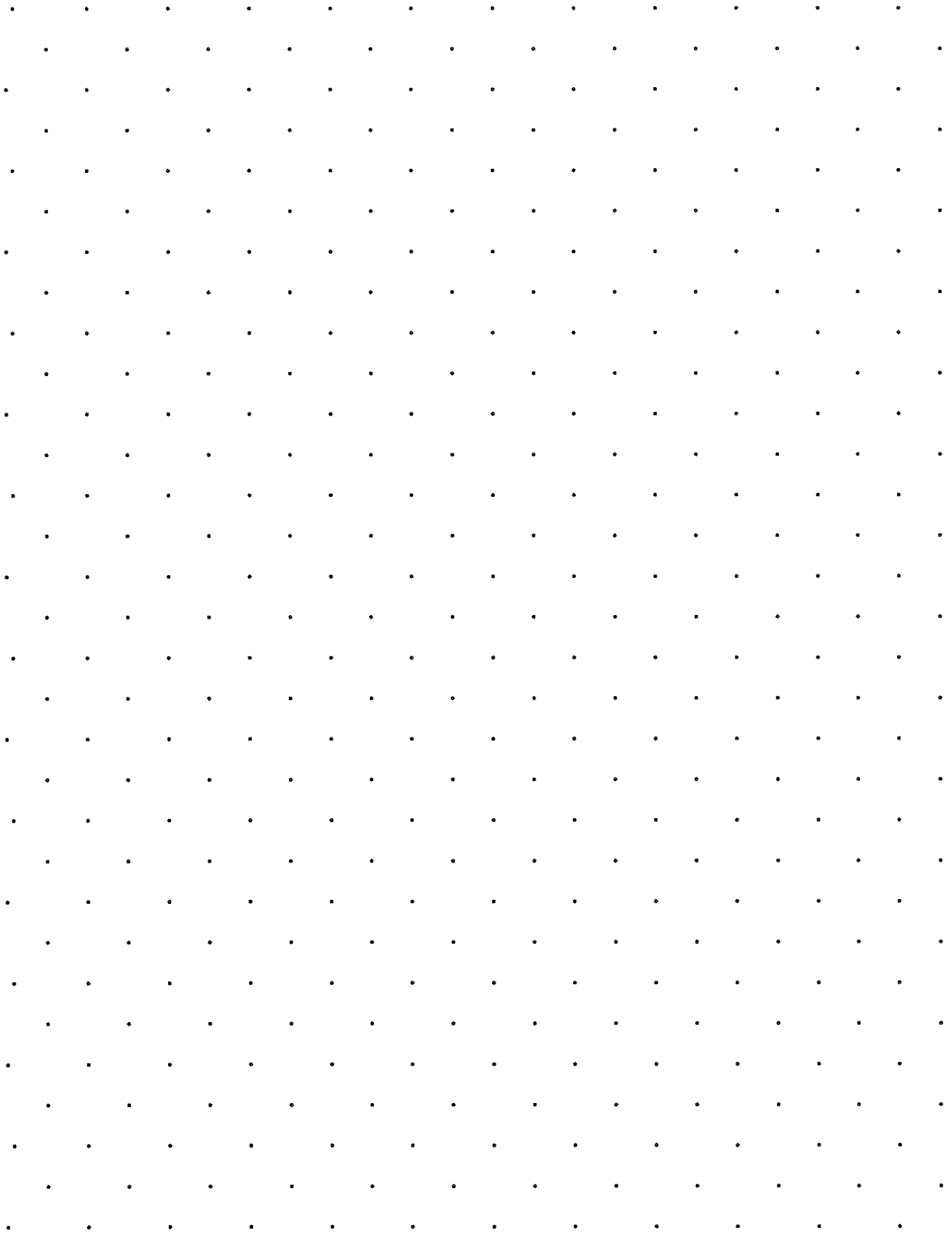



NET OF A CUBE 1

**Cube Pattern**  
Cut on solid lines - Fold on dashed lines

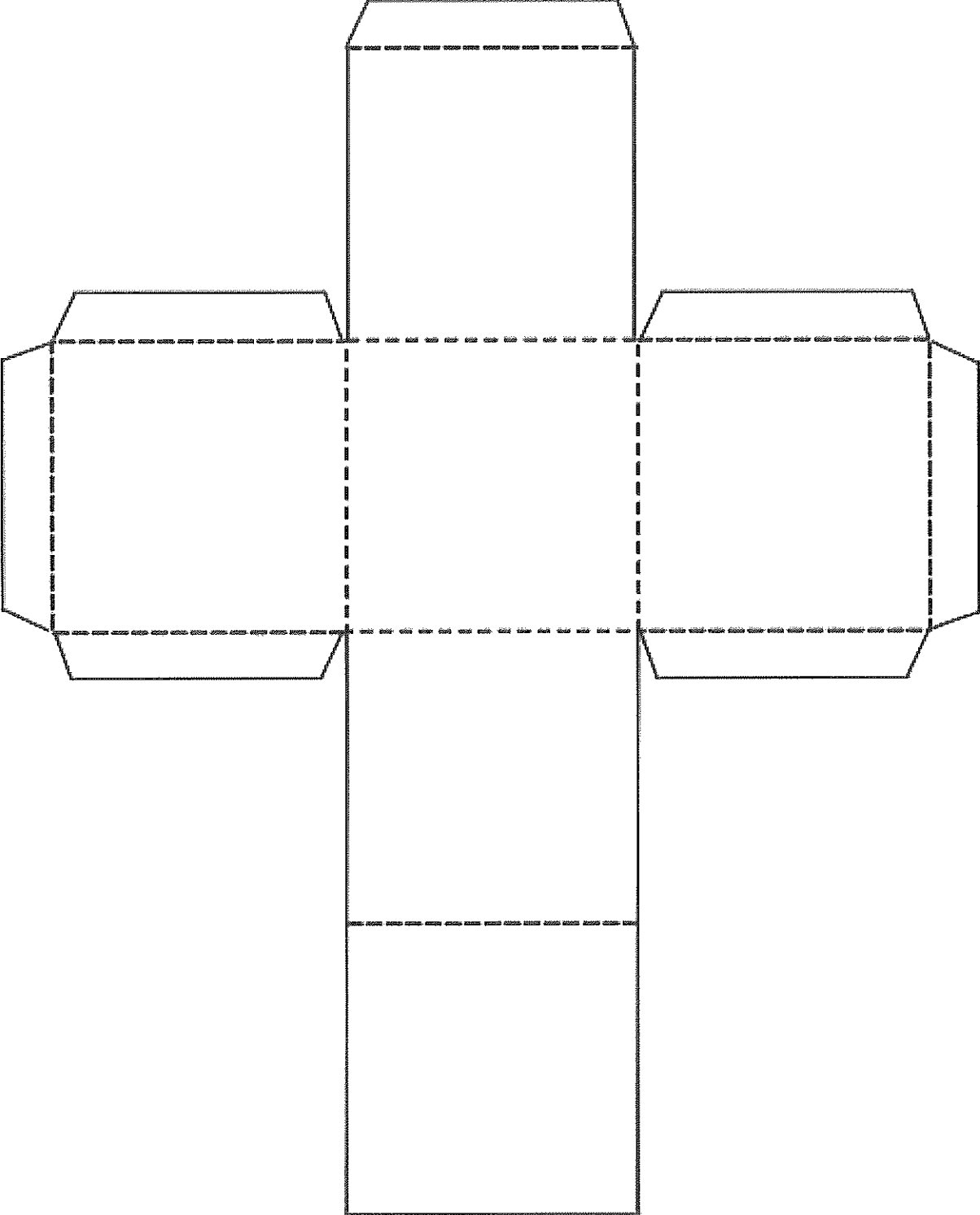



NET OF A CUBE 2

Cube Pattern  
Cut on solid lines - Fold on dashed lines

